

OFFICE IN THE PARK

BEACHWOOD, OHIO



24400 HIGHPOINT ROAD
BEACHWOOD, OHIO

1,100 Rentable Square Feet
2 Offices with Windows
Conference Room
Wood & Brick Accent Walls

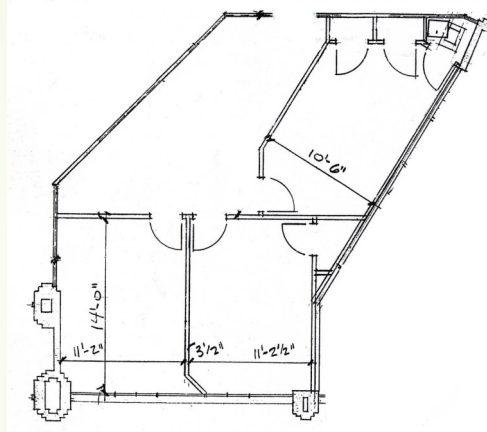

24400 HIGHPOINT ROAD, BEACHWOOD, OHIO 44122

\$11.00 PRSF + NETS / LAST SPACE 1,100 SF

OPERABLE WINDOWS / SEPARATE HVAC UNITS / HIGHLY LANDSCAPED

BYPASS CHAGRIN I / 271 AND USE THE HARVARD EXIT!

PRIVATE ENTRANCES / VERY QUIET AND SERENE / BRICK AND WOOD ACCENTS



EGAR
ASSOCIATES INC.

STEVEN EGAR, SIOR

egaronline.com

SEGAR@EGARONLINE.COM

216 360.9090 EXT 21 : OFFICE

216 789-9090 : CELL



EGAR
ASSOCIATES INC.

OFFICE IN THE PARK



24400 Highpoint Road, Beachwood, Ohio 44122
Suite 5. 1,100 Rentable Square Feet

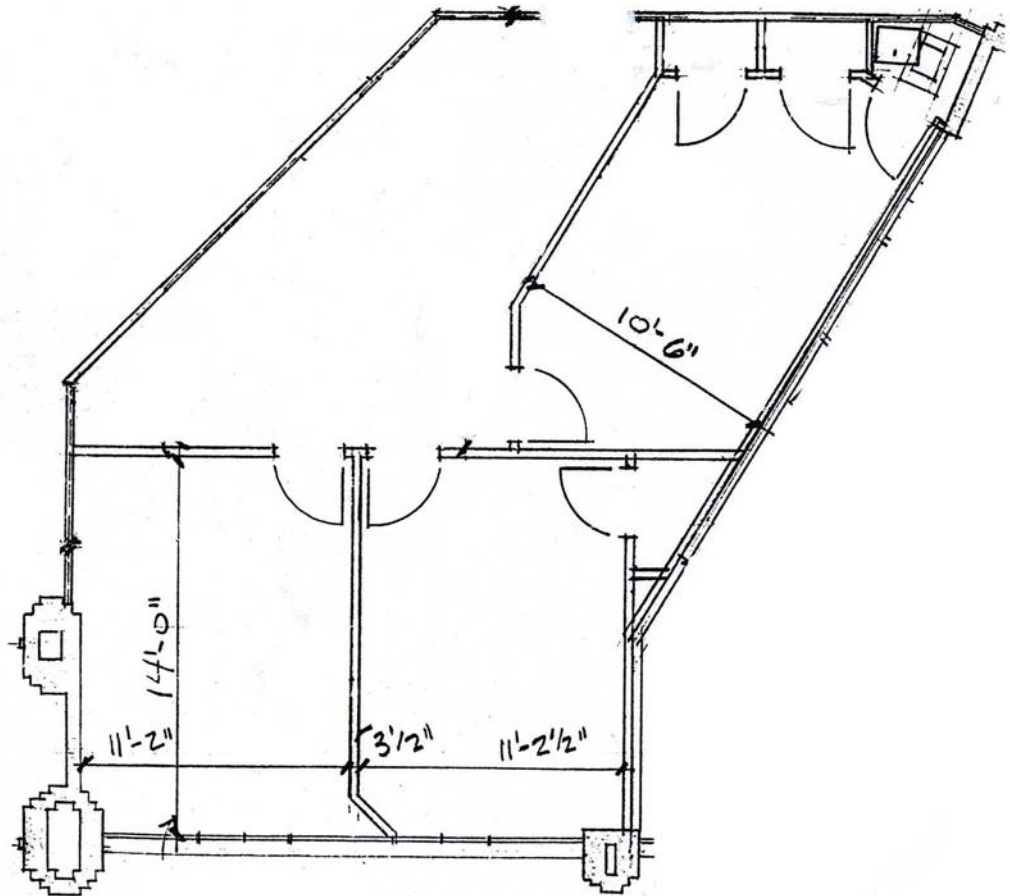

For more information call Steven Egar, SIOR
(216) 360-9090 ext. 21 / 216 789-9090 Cell
segar@egaronline.com

COMMERCIAL
REAL ESTATE
SERVICES

24100 Chagrin Blvd.

Suite 435

Beachwood, OH 44122-5546

Tel (216) 360.9090

Fax (216) 360.9091

egaronline.com

Individual Membership
Society of Industrial and Office REALTORS®



EGAR
ASSOCIATES INC.

OFFICE IN THE PARK



FACT SHEET

24400 HIGHPOINT ROAD., BEACHWOOD, OHIO 44122

Total Building Size:	Approximately 14,586 rentable square feet.
BOMA factor:	Ten (10% percent).
Number of Floors:	One.
Rental Rate:	\$12.00 per rentable square foot.
Escalation's:	Triple Net. Tenant is responsible for a pro rata share of the real estate taxes, insurance, and maintenance. 2013 NNN = Approx. \$6.55 RSF.
Cleaning:	Five nights per week.
Management:	Owner managed by Harsax, Inc.
Unique Characteristics:	9' ceiling height, operable windows, 3 Atriums. Landscaping graded at window height. Access to I-271 at Chagrin Blvd or at Harvard Rd.
Parking:	Abundant surface parking at all three entrances.
HVAC:	Tenants have 24 hour control of the heating and air conditioning at Tenant's expense.
Contact:	Steven Egar, SIOR. (216) 360-9090 Ext. 21. segar@egaronline.com Cell: 216 789-9090

**COMMERCIAL
REAL ESTATE
SERVICES**

24100 Chagrin Blvd.

Suite 435

Beachwood, OH 44122-5546

Tel (216) 360.9090

Fax (216) 360.9091

The information submitted herein is not guaranteed. Although obtained from reliable sources, it is subject to errors, omissions prior sale and withdrawal from the market without notice. Seller and broker make no representation as to the environmental condition of the property and recommend purchasers independent investigation.

e g a r o n l i n e . c o m

Individual Membership
Society of Industrial and Office REALTORS®